

# The BOSS 175/300

Heavy-Duty Floor Machine  
Interchangeable Aprons  
175 / 300 RPM Dual Speed  
13", 15" 17", 19" and 21" Aprons

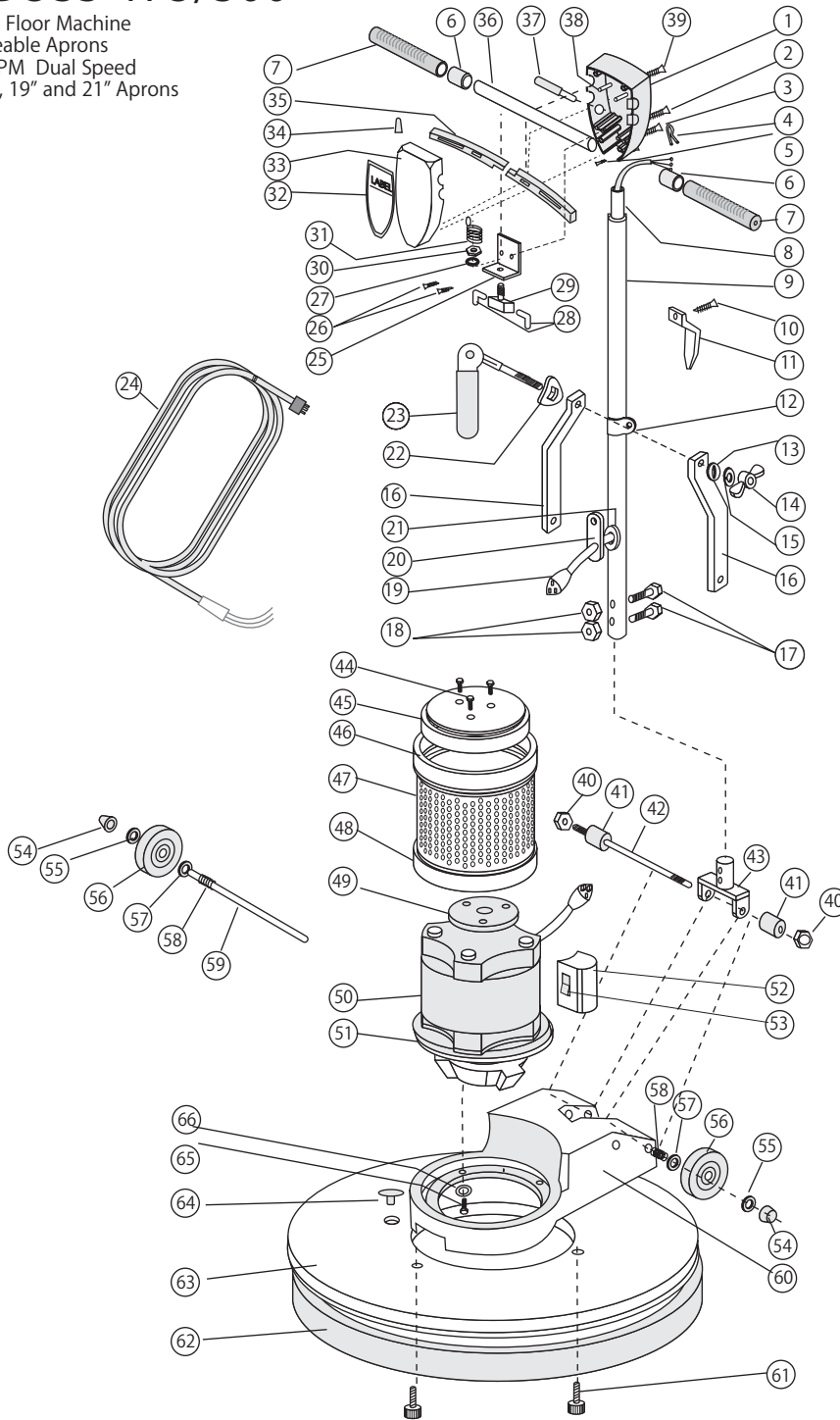

Number	Description	PART #	# Required
1	Switch Box Back	A-104	1
2	Handle Tube Screw	B-23	2
3	Switch Box Closing Screw	B-21	4
4	Strain Relief Clip	M-213	1
5	Ground Wire Screw	B-68	2
6	Rubber Spacer	M-218 Y	2
7	Hand Grip	M-218	2
8	Handle Tube Insert	M-247	1
9	Handle Tube Assembly	M-206	1
10	Cable Hook Screw	B-2	2
11	Cable Hook	A-164	1
12	Sliding Collar	A-111	1
13	Oval Hole Cam Washer	B-37	1
14	Cam Lock Wing Nut	B-25	1
15	Cam Split Washer	B-39	1
16	Bent Brace	M-216	2
17	Yoke Bolt	B-18A	2
18	Yoke Nut	B-19	2
19	Handle Tube Cable	G-16	1
20	Black Rubber Cable Connector	M-249	1
21	Cable Grommet	B-63	1
22	Rectangular Hole Cam Washer	B-67	1
23	Complete Cam Assembly	CCA	1
24	50 Foot Cable 14/3 Yellow	G-14-50-Y	1
25	Switch Mounting Plate	G-30-B	1
26	Switch Plate Screw	B-1	2
27	Int. Tooth Lock Washer (For Switch)	B-35	1
28	Insulated Flag Wire Connector	G-48	2
29	On-Off Switch And Plate Assembly	G-30-AB	1
30	Lock Washer	B-33	1
31	Trigger Return Spring	G-30-CT057	1
32	Label For Switch Box	CALL FOR #	1
33	Switch Box Front	A-103	1
34	Wire Connector	G-47	1
35	Trigger	A-105	2
36	16" Crossbar	M-211-A	1
37	Safety Interlock Assembly	SIA-1	1
38	Trigger Pin	B-70	2
39	Crossbar Screw	B-22	2
40	Acorn Nut For Yoke Pin	B-8	2
41	Rubber Yoke Spacer	B-5	2
42	Yoke Pin	B-7	1
43	Yoke	A-1001	1
44	Drip Cap Mounting Screw	B-151	3
45	66 Frame Drip Cap Cover	M-242	1
46	66 Frame Drip Cap Cover Bumper	M-239	1
47	Two-Speed Motor Screen	SCR-02	1
48	Two-Speed Motor Screen Bumper	M-238-1	1
49	Cork Drip Cap Gasket	M-248	1
50	Two-Speed D/C Motor, 66 Frame 1.5 HP With Gearbox	SRR-01	1
51	Gear Box, 11:1, Triple Planetary	GB96008	1
52	Two-Speed Hi-L o Switch Box	SCAP-2	1
53	Two-Speed Hi-L o Switch	HIL0-TS	1
54	Hub Caps	V0038	2
55	Spring Washer	B-51	4
56	6" Wheels	M-245	2
57	1/2" Flat Washer	B-29	2
58	Spring	B-30	2
59	Axel	M-240	1
60	Main Machine Frame	A-166	1
61	Thumb Screw - Apron Mounting	B-96	3
62E	Bumper 13"	M-232-13	1
62A	Bumper 15"	M-232-15	1
62B	Bumper 17"	M-232-17	1
62C	Bumper 19"	M-232-19	1
62D	Bumper 21"	M-232-21	1
63B	Apron 13"	A-173	1
63B	Apron 15"	A-167	1
63B	Apron 17"	A-169	1
63C	Apron 19"	A-171	1
63D	Apron 21"	A-172	1
64	Scrubber Plug	B-50	1
65	Base Casting Screw	B-95	3
66	1/4" Medium Split Washer (現行商品未使用)	B-32	3